

1.7" - 100W Compression Driver

CD 96.44/235 8 Ω

Code Z009493

GENERAL CHARACTERISTICS		
Nominal Overall Diameter	96	mm
Nominal Voice Coil Diameter	44	mm
Magnet Weight	235	g
Flux Density.....	2.10	T
Weight.....	1.00	Kg

THIELE-SMALL PARAMETERS			
Voice Coil DC Resistance	R_E	5.80	Ω
Resonance Frequency	f_s	800	Hz

CONSTRUCTIVE CHARACTERISTICS	
Magnet.....	Neodymium
Voice Coil Winding.....	Aluminium Flat Wire
Voice Coil Former.....	Kapton
Voice Coil Winding Height.....	2.6 mm
Diaphragm	Titanium
Air Gap Height.....	2.5 mm
Ferrofluid in Air Gap	No
Throat Diameter	25 mm
Horn.....	- - -

NOTES
 Mounting informations:
 2 M5 holes 180° on 76mm diameter

ELECTRICAL CHARACTERISTICS		
Nominal Impedance.....	8	Ω
Musical Power	100	W
Rated Power*	50	W
Sensitivity @ 1 W, 1 m	107.0	dB

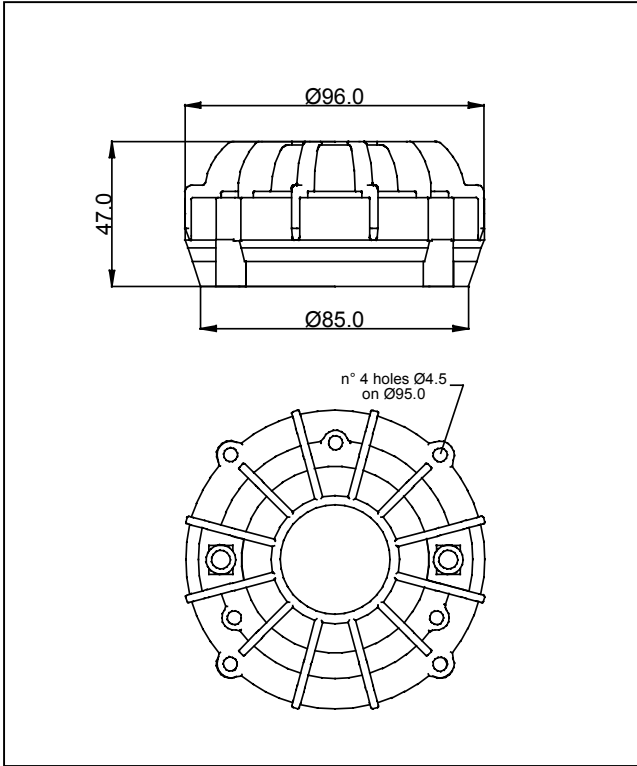

*rated power measured with 2 hours test with continuous pink noise signal, 6 dB crest factor, HP filter 3kHz-12dB/Oct

Free Air Frequency Response with horn @ 1 W, 1 m - Impedance (without horn)

Due to continuing product improvement, the features and the design are subject to change without notice.

27/03/06

