

10" - 500W Bass Guitar Loudspeaker

10 BS 2,5 PL - 16 Ω

Code Z005911

GENERAL CHARACTERISTICS

Nominal Overall Diameter	268	mm
Nominal Voice Coil Diameter	65	mm
Magnet Weight	220	g
Flux Density.....	1.14	T
Weight.....	2.22	Kg

THIELE-SMALL PARAMETERS

Voice Coil DC Resistance	R_E	11.85	Ω
Resonance Frequency	f_s	59.9	Hz
Mechanical Q Factor.....	Q_{MS}	7.71	
Electrical Q Factor.....	Q_{ES}	0.70	
Total Q Factor	Q_{TS}	0.64	
Mechanical Moving Mass	M_{MS}	34.9	g
Mechanical Compliance	C_{MS}	202	μm/N
Force Factor	$B \times l$	14.93	Wb/m
Equivalent Acoustic Volume.....	V_{AS}	34.3	lt.
Maximum Linear Displacement	X_{MAX}	+/-5.0	mm
Reference Efficiency	η_0	1.01	%
Diaphragm Area	S_D	346.3	cm ²
Losses Electrical Resistance.....	R_{ES}	130.9	Ω
Voice Coil Inductance @ 1kHz	L_E	1.10	mH

CONSTRUCTIVE CHARACTERISTICS

Magnet.....	Neodymium
Voice Coil Winding.....	Aluminium
Voice Coil Former.....	Kapton
Cone	Treated Paper
Surround.....	Treated Cloth
Dust Dome	Solid Paper
Basket	Aluminium Die-Cast

ELECTRICAL CHARACTERISTICS

Nominal Impedance.....	16	Ω
Musical Power	500	W
Rated Power*	250	W
Sensitivity @ 1 W, 1 m	93.6	dB

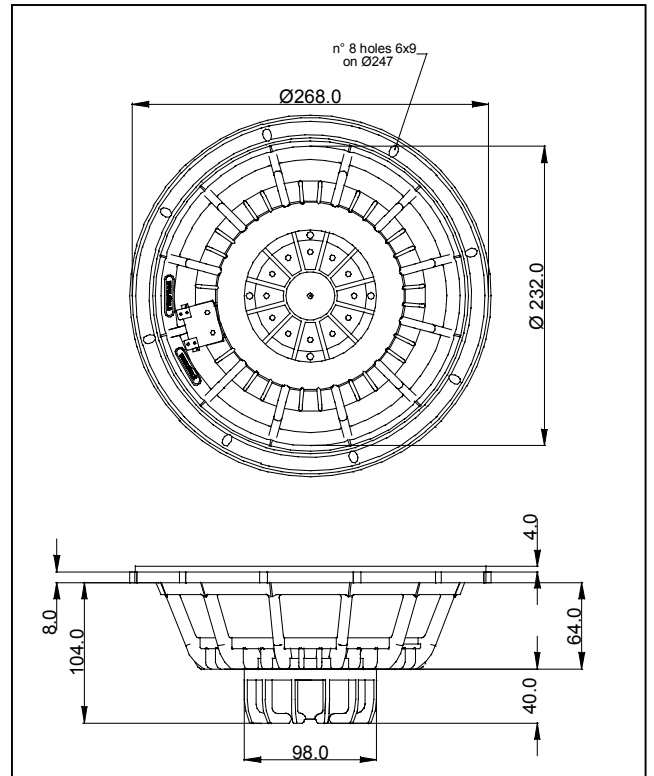

*rated power measured with 2 hours test with pink noise signal, 6 dB crest factor, loudspeaker mounted on enclosure
Thiele-Small parameters measured with LASER system

Frequency Response on IEC Baffle (DIN 45575) @ 1 W, 1 m - Impedance

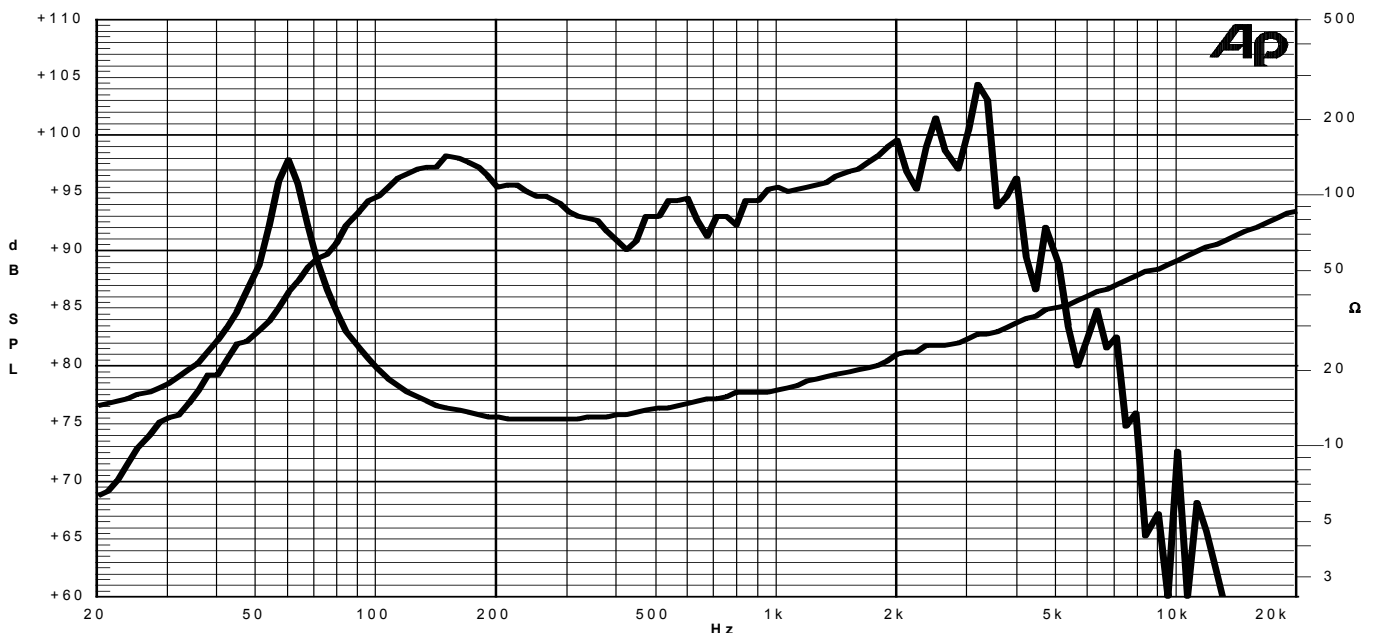

Due to continuing product improvement, the features and the design are subject to change without notice.

31/05/07