

ND1030

Neodymium High Frequency Driver

Key Features

- 107 dB SPL 1W / 1m average sensitivity
- 1 inch exit throat
- 34,4 mm (1 1/3 inch) voice coil diameter
- 60 Watt continuous program power handling
- Pure Titanium diaphragm
- Patented phase plug design
- Neodymium magnetic structure



General Description

The ND1030 has been designed for use in high quality two-way audio systems. With a 1-inch throat exit, the ND1030 has been developed to match the XT1086 and the XT120 constant directivity horns.

The ND1030 exhibits a constant slope response from 1.5kHz to 18kHz with a uniform and smooth roll-off. With a 900Hz free air resonance frequency, the ND1030 can easily be cut-off at 1800Hz and is capable of 60W continuous power handling with a 1800Hz pink-noise signal, and a 6dB crest factor with a minimum 12dB/oct crossover slope.

Equipped with unique Phase Plug architecture (Patent n. WO 2004/040942), the ND1030 has been designed to give a smooth coherent wavefront at the horn entrance in the whole working frequency range, as well as high level manufacturing consistency. The phase plug with its short openings and high flare rate value assures low distortion and demonstrates remarkable improvements in mid-high frequency reproduction.

The ND1030 titanium diaphragm assembly, with its ellipsoidal suspension shape, exhibits a constant slope response from 1kHz to 18kHz with uniform smooth roll-off behavior. An edge-wound aluminum voice coil, wound on proprietary treated Nomex, completes the diaphragm assembly. Nomex shows a 30% higher value of tensile elongation at a working operative temperature (200°C) when compared to Kapton. This feature enables proper energy transfer control from the voice coil to the dome in real working conditions. Moreover, this proprietary former material is also suitable for use in higher moisture content environments.

The big innovation in the ND1030 is the magnetic architecture. By careful use of elementary pieces of neodymium magnets, Eighteen Sound engineers have developed a powerful neodymium magnet assembly capable of reaching 18KGauss in the gap within a compact and lightweight structure.

0421M8N800

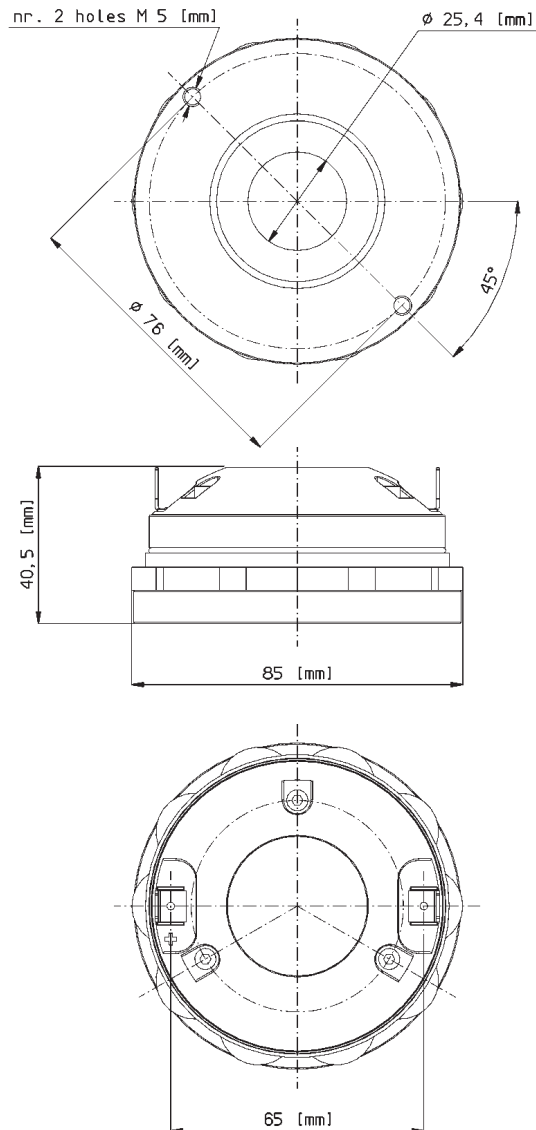

NEODYMIUM HF DRIVERS

ND1030

Neodymium High Frequency Driver

GENERAL SPECIFICATIONS

THROAT DIAMETER	25,4 mm (1 in)
RATED IMPEDANCE	8 ohm
DC RESISTANCE	5,8 Ohm
MINIMUM IMPEDANCE	6,5 Ohm at 5000Hz
LE (AT 1KHZ)	54 µH
POWER HANDLING	
CONTINUOUS PINK NOISE (1)	30W above 2 kHz
CONTINUOUS PROGRAM (2)	60W above 2 kHz
SENSITIVITY(1W@1M) (3)	107 dB
FREQUENCY RANGE	1800Hz ÷ 20kHz
RECOMM. XOVER FREQUENCY	1800Hz
DIAPHRAGM MATERIAL	Titanium
VOICE COIL DIAMETER	34,4 mm (1 1/3 in)
VOICE COIL WINDING MATERIAL	Edge-wound aluminum
MAGNET MATERIAL	Neodymium
FLUX DENSITY	1,8 T
BL FACTOR	6 N/A
POLARITY	Positive voltage on red terminal gives positive pressure in the throat

MOUNTING INFORMATIONS

Overall diameter	85 mm (3,3 in)
Mounting holes diameter	2 M5 holes on Ø 76 mm (3 in)
Bolt circle diameter	58 mm (2,3 in)
Total depth	40,5 mm (1,6 in)
Net weight	0,8 kg (1,75 lb)
Shipping weight	0,9 Kg (1,97 lb)
CardBoard Packaging dimensions	97x97x58 mm (3,8x3,8x2,3 in)

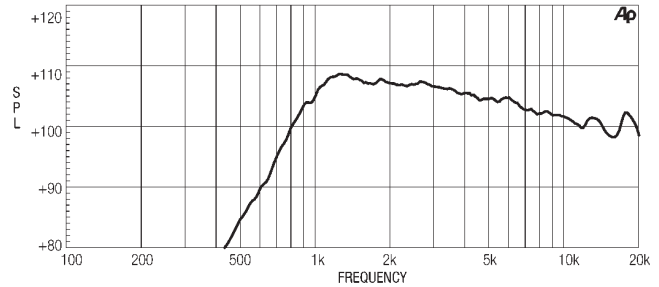
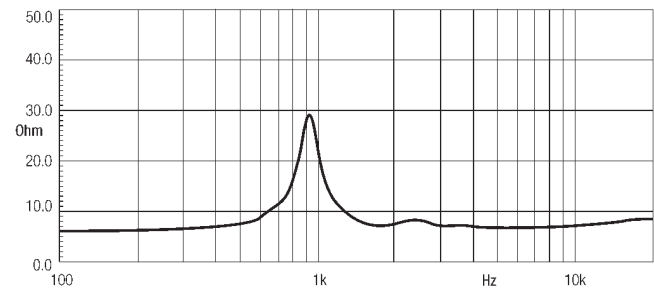
ND1030 MEASURED WITH 1W INPUT ON RATED IMPEDANCE AT 1M DISTANCE ON XT1086HORN MOUTH AXIS**FREE AIR IMPEDANCE MAGNITUDE CURVE****NOTES**

- (1) Continuous pink noise power rating is tested with a pink noise input having a 6 dB crestfactor for two hours duration within the specified range. Power calculated on minimum impedance.
- (2) Program Power is defined as 3 dB greater than continuous pink noise but with 50% duty cycle.
- (3) Sensitivity is measured at 1W input on rated impedance at 1m on axis from the mouth of XT1086 averaged between 1kHz and 4 kHz.

Eighteen Sound engages in research and product improvement. New materials and design refinements can be introduced into existing products without notice.