

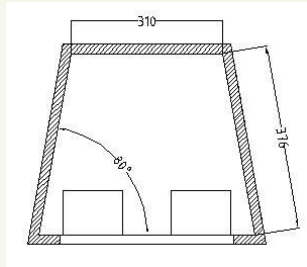

# Box 15

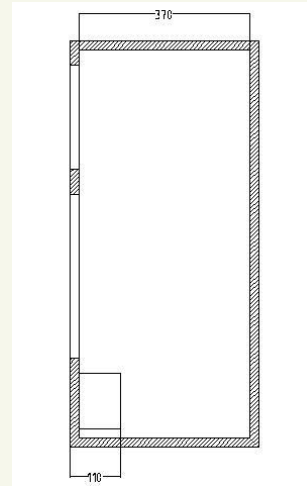
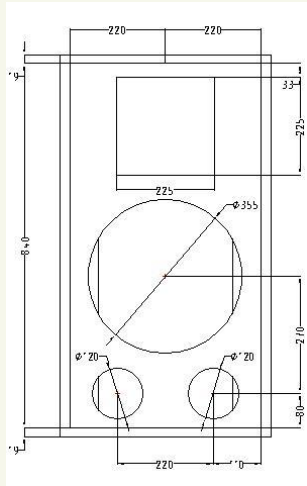

## Specifications

LF Driver	15PLB76
HF Driver	DE610
Horn	DE90
Cabinet Type	Bass Reflex
Box Volume	114 dm <sup>3</sup>
Tuning Frequency	45 Hz
Crossover Frequency	1.2 kHz
Nominal Impedance	8 ohm
Minimum Impedance	6.5 ohm
Frequency Range	45 - 16000 Hz
Nominal Power Handling	350 W
Continuous Power Handling	700 W
Sensitivity (1W/1m)	99 dB
Max. Peak SPL	133 dB
Max. Long Term SPL	127 dB

