

#### GENERAL CHARACTERISTICS

Nominal Overall Diameter .....	266	mm
Nominal Voice Coil Diameter .....	25	mm
Magnet Weight .....	280	g
Flux Density.....	0.90	T
Weight.....	1.30	Kg

#### THIELE-SMALL PARAMETERS

Voice Coil DC Resistance .....	$R_E$	6.87	Ω
Resonance Frequency .....	$f_s$	76.1	Hz
Mechanical Q Factor.....	$Q_{MS}$	19.52	
Electrical Q Factor.....	$Q_{ES}$	1.70	
Total Q Factor .....	$Q_{TS}$	1.56	
Mechanical Moving Mass .....	$M_{MS}$	15.2	g
Mechanical Compliance .....	$C_{MS}$	287	μm/N
Force Factor .....	$B \times l$	5.44	Wb/m
Equivalent Acoustic Volume.....	$V_{AS}$	43.9	lt.
Maximum Linear Displacement ....	$X_{MAX}$	+/-1.5	mm
Reference Efficiency .....	$\eta_0$	1.10	%
Diaphragm Area .....	$S_D$	330.0	cm <sup>2</sup>
Losses Electrical Resistance.....	$R_{ES}$	79.1	Ω
Voice Coil Inductance @ 1kHz .....	$L_E$	0.45	mH

#### CONSTRUCTIVE CHARACTERISTICS

Magnet.....	Ferrite
Voice Coil Winding.....	Copper
Voice Coil Former.....	Epotex
Cone .....	Paper
Surround.....	Paper - Integrated
Dust Dome .....	Dual-Cone
Basket .....	Pressed Sheet Steel

#### ELECTRICAL CHARACTERISTICS

Nominal Impedance.....	8	Ω
Musical Power .....	120	W
Rated Power* .....	60	W
Sensitivity @ 1 W, 1 m .....	93.1	dB

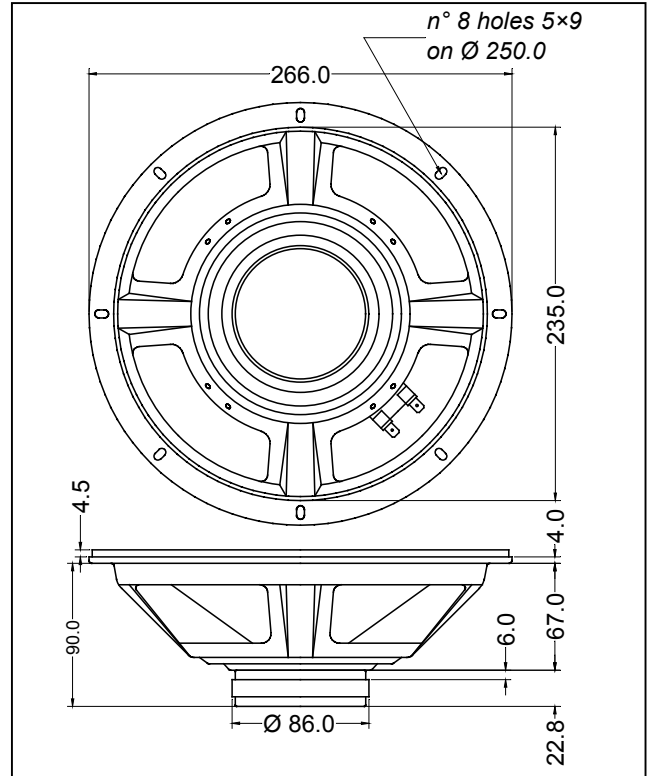

\*rated power measured with 2 hours test with pink noise signal, 6 dB crest factor, loudspeaker mounted on enclosure

Frequency Response on IEC Baffle (DIN 45575) @ 1 W, 1 m - Impedance

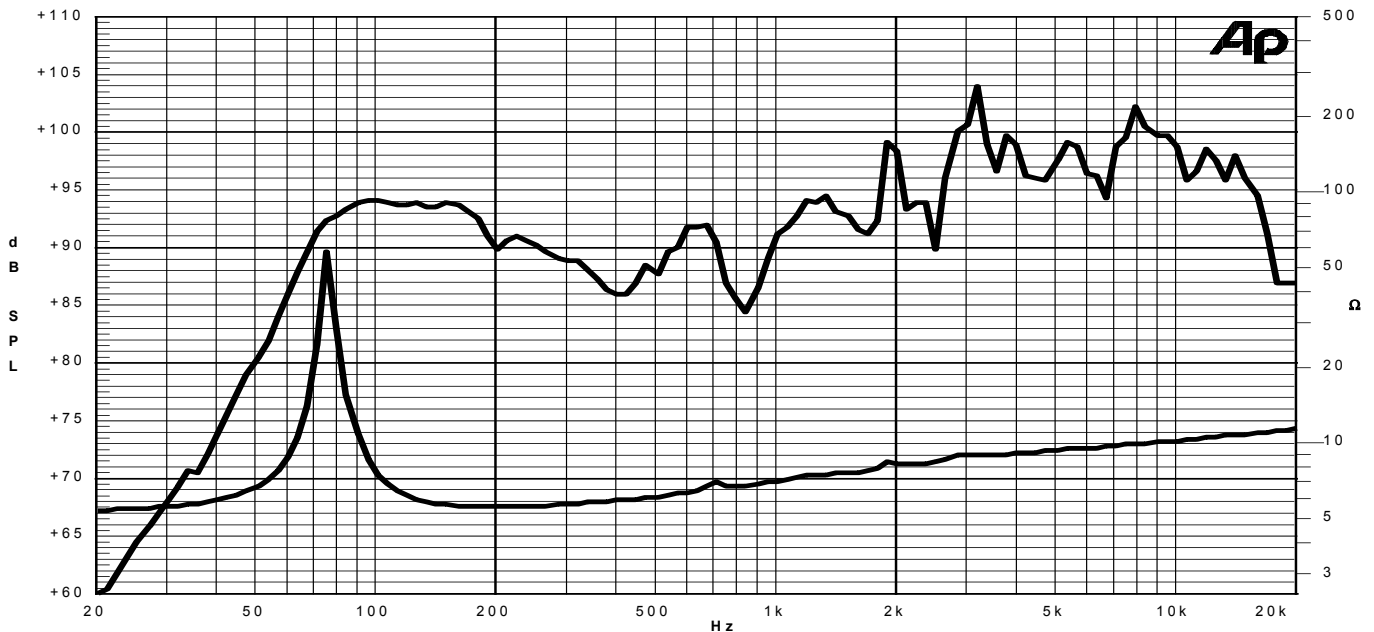

Due to continuing product improvement, the features and the design are subject to change without notice.

14/03/05