

8CX400F

High Output Coaxial Transducer

Key Features

- 95dB SPL 1W / 1m average sensitivity
- 300 W continuous pink noise handling
- 51mm (2 inches) LF Interleaved Sandwich Voice coil (ISV)
- FEA computer modelling horn profile
- 25,4mm (1 inch) edgewound voice coil HF compression driver
- 90 degrees nominal dispersion
- Ideal for compact reflex two way and multi-way systems



General Description

The 8CX400 coaxial transducer has been developed in response to a specific market requirement for an 8 inch - 1 inch coaxial driver combining excellent linearity with good efficiency and power handling capabilities.

It is primarily intended for compact reflex enclosures and, because of its versatile characteristics, may also be used in multiway systems or ceiling applications. Its nominal dispersion is 90 degrees.

The curvilinear, paper LF section cone is formed using a unique wood pulp composition designed to achieve the best possible rigidity and stiffness. A polycotton multiroll surround to provide increased excursion whilst controlling break up modes carries it.

The 51mm Ø state-of-the-art, aluminum wire voice coil employs same technology of that fitted to our top-of-the-range models using our Interleaved Sandwich Voice coil (ISV) technology. In essence, a high strength Fiberglas former is used to carry windings on both the outer and inner surfaces to achieve a mass balanced coil. This results in an extremely linear motor assembly, which, in conjunction with the highly advanced design of the magnetic structure, provides a high force factor or BL.

The high frequency driver incorporates a polyester material diaphragm for best movement and stress control; the special radial ribs increase stiffness avoiding uncontrolled vibration modes in the usable frequency range. An edge-wound copper clad aluminum voice coil wounded on treated Nomex completes the diaphragm assembly. A computer aided FEA has been used in order to maximize the cone profile coupling and to control the energy in the desired frequency range.

With the increasing use of outdoor audio events, the ability to perform in humid environments is another feature of the 8CX400F. This is achieved by means of exclusively developed humidity repellent cone treatment.

02208CX10 80hm

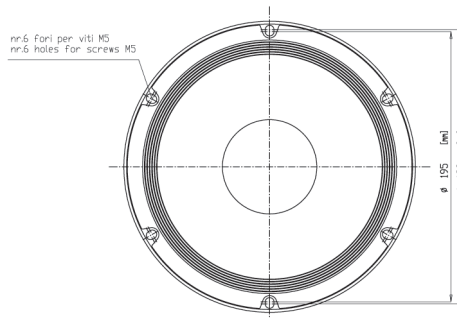
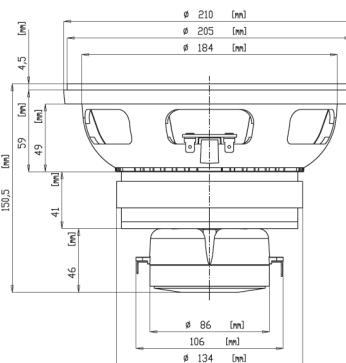

FERRITE LF-MB-MF TRANSDUCERS

8CX400F

High Output Coaxial Transducer

LF GENERAL SPECIFICATIONS

NOMINAL DIAMETER	200 mm (8 in)
RATED IMPEDANCE	8 Ohm
CONTINUOUS PINK NOISE (1)	280 W
CONTINUOUS POWER (2)	200 W
PROGRAM POWER (3)	400 W
PEAK POWER (4)	800 W
SENSITIVITY (5)	95 dB
FREQUENCY RANGE (6)	65 ÷ 6100 Hz
POWER COMPRESSION @-10DB (7)	0,5 dB
POWER COMPRESSION @-3DB	1,4 dB
POWER COMPRESSION @0 DB	2,3 dB
MAX RECOMM. FREQUENCY	2800 Hz
RECOMM. ENCLOSURE VOLUME	10 ÷ 40 lt. (0,35 ÷ 1,41 cuft)
MINIMUM IMPEDANCE	6,1 Ohm at 25°C
MAX PEAK TO PEAK EXCURSION	19 mm (0,75 in)
VOICE COIL DIAMETER	51 mm (2 in)
VOICE COIL WINDING MATERIAL	aluminum

HF GENERAL SPECIFICATIONS

D.C. RESISTANCE	8,3 Ohm
POWER HANDLING	
- CONTINUOUS PINK NOISE (8)	25 W above 2,5 kHz
- CONTINUOUS PROGRAM (9)	50 W above 2,5 kHz
SENSITIVITY (10)	106 dB
FREQUENCY RANGE	2,5 kHz ÷ 20 kHz
RECOMM. XOVER FREQUENCY	3 kHz 12 dB/oct
VOICE COIL DIAMETER	25,4 mm (1,0 in)

THIELE SMALL PARAMETERS (11)

Fs	64 Hz
Re	5 Ohm
Sd	0,0227 sq.mt. (35,2 sq.in.)
Qms	3,23
Qes	0,43
Qts	0,38
Vas	23,9 lt. (0,85 cuft)
Mms	18 gr. (0,04 lb)
BL	9,3 Tm
Mathematical Xmax (12)	± 5,8 mm (± 0,23 in)
Le (1kHz)	0,96 mH
Ref. Effic. 1W@1m (1/2space)	93,7 dB

MOUNTING INFORMATIONS

Overall diameter	210 mm (8,27 in)
N. of mounting holes	6
Mounting holes Ø	6,25 mm (0,25 in)
Bolt circle Ø	195 - 198 mm (7,68 - 7,80 in)
Front mount baffle cutout Ø	186 mm (7,32 in)
Rear mount baffle cutout Ø	184 mm (7,24 in)
Total depth	150,5 mm (5,93 in)
Flange and gasket thickness	14,5 mm (0,57 in)
Net weight	4,4 kg (9,76 lb)
Shipping weight	5,0 kg (11,1 lb)
CardBoard Packaging Dim.	235x235x165 mm (9,25x9,25x6,46 in)

FREQUENCY RESPONSE CURVE OF 8CX400 MADE ON 25LT ENCLOSURE TUNED AT 65HZ IN FREE FIELD (4PI) ENVIRONMENT. ENCLOSURE CLOSES THE REAR OF THE DRIVER. THE THIN LINE REPRESENTS HIGH FREQUENCY RESPONSE.

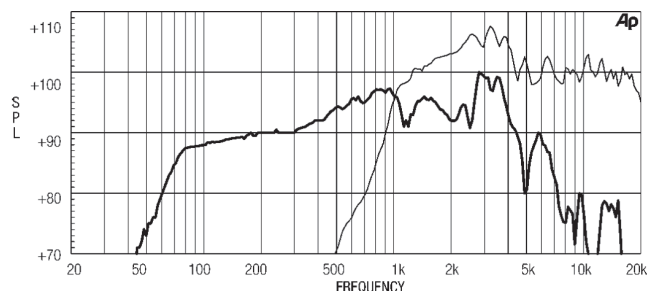

FREE AIR IMPEDANCE MAGNITUDE CURVE

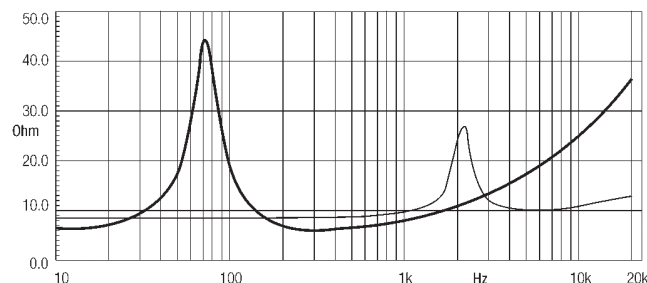

NOTES

- (1) AES standard
- (2) Continuous power rating is measured in 25lit enclosure tuned 65Hz using a 60 - 2000Hz band limited pink noise test signal applied continuously for 2 hours.
- (3) Program power rating is measured as for 2 above but 50% duty cycle.
- (4) The peak power rating is based on a 6dB crest factor above the continuous power rating and represents the maximum permitted instantaneous peak power level over a maximum period of 10ms which will be withstood by the loudspeaker without damage.
- (5) Sensitivity represents the averaged value of acoustic output as measured on the forward central axis of cone, at distance 1m from the baffle panel, when connected to 2,83 V sine wave test signal swept between 500Hz and 2500Hz with the test specimen mounted in the same enclosure as given for 2 above.
- (6) Frequency range is given as the band of frequencies delineated by the lower and upper limits where the output level drops by 10 dB below the rated sensitivity in 1/2 space environment.
- (7) Power compression represents the loss of sensitivity for the specified power, measured from 50-500 Hz, after a 5 min pink noise preconditioning test at the specified power.
- (8) Continuous pink noise power rating is tested with pink noise input having a 6dB crest factor for 2 hours duration within the specified range. Power calculated on rated impedance.
- (9) Continuous program power is defined as 3 dB greater than continuous pink noise and is a conservative expression of the transducer ability to handle music program material.
- (10) Sensitivity is measured on 1W input on rated impedance at 1m on axis from the mouth of the woofer and averaged in 3kHz band.
- (11) Thiele - Small parameters are measured after the test specimen has been conditioned by 280 W AES power and represent the expected long term parameters after a short period of use.
- (12) Linear Mat. Xmax is calculated as $(Hvc-Hg)/2 + Hg/4$. Hvc is the coil depth and Hg is gap depth.

Eighteen Sound engages in research and product improvement. New materials and design refinements can be introduced into existing products without notice.

