

10NDA610

High Output Midrange Neodymium Transducer

Key Features

- 103 dB SPL 1W / 1m average sensitivity (AIC on)
- 75 mm (3 in) Interleaved Sandwich Voice coil (ISV)
- 400 W continuous pink noise power handling
- Neodymium motor assembly
- A.I.C. (Active Impedance Control) technology
- Extremely high sound quality
- Very shallow profile, 90 mm (3,5 in)
- Humidity resistant



General Description

The 10NDA610 is a high power, very high output, state-of-the-art midrange transducer for high quality professional use. The high level of sound reproduction is achieved thanks to extensive research by Eighteen Sound engineers, which focused on implementing mid frequencies intelligibility.

The 10NDA610 is ideally used as a midrange in both horn and direct radiation, closed or reflex enclosures, as small as 4 liters. The 10NDA610 incorporates an Active Impedance Control (A.I.C.) consisting of an additional coil fixed on the pole piece and connected in parallel to the moving coil.

The magnetic field generated by this coil has the following effects:

- 1) Impedance linearization
- 2) Acoustic and electric phase linearization
- 3) Significant increase of sensitivity and total SPL
- 4) Total harmonic distortion reduction
- 5) Constant power transfer

The A.I.C. offers substantial advantages to the sound quality by not absorbing the moving coil's electromagnetic energy.

The extremely powerful external neodymium magnet assembly assures high flux concentration, low power compression and excellent heat exchange. The levels of force factor and power handling are consequently at a top professional level, with the best power to weight ratio on the market today.

The curvilinear cone, made with a high damping wood pulp, has been designed to achieve the best possible linearity within its frequency range. The in-house developed cone treatment acts as humidity repellent and significantly dampens bell mode resonances. The 75mm edge-wound voice coil assembly is wound on a strong fiberglass former to improve force transmission and power handling. A proprietary humidity-block cone treatment makes the transducer suitable for outdoor use in adverse weather conditions. In addition, a special coating applied to both the top and back plates makes the 10NDA610 far more resistant to the corrosive effects of salts and oxidization.

022108N210 8 Ohm

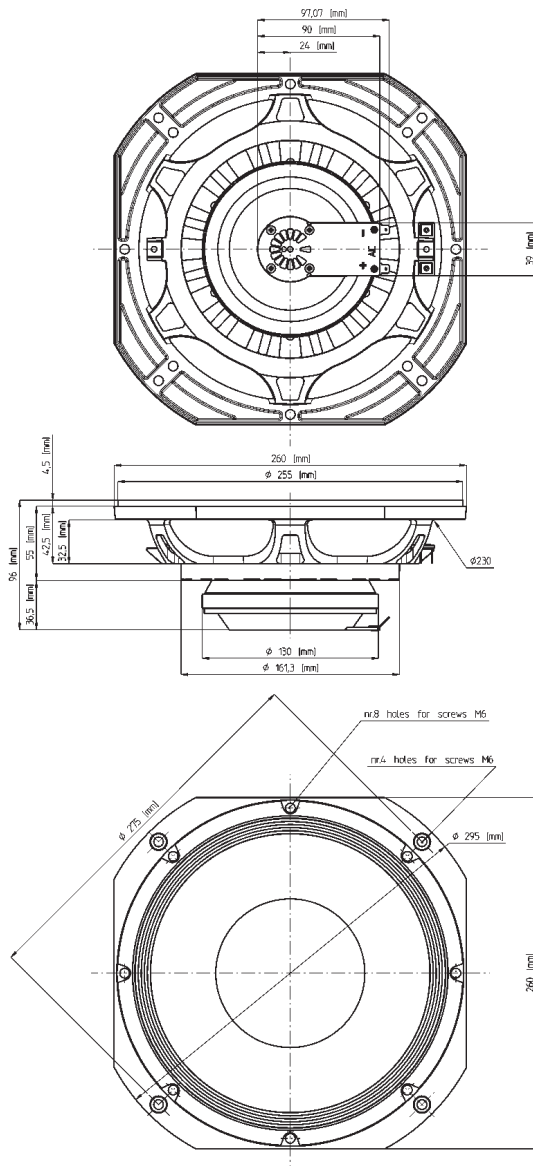

NEODYMIUM LF-MB-MF TRANSDUCERS

10NDA610

High Output Midrange Neodymium Transducer

GENERAL SPECIFICATIONS

NOMINAL DIAMETER	260mm (10 in)
RATED IMPEDANCE	8 Ohm
CONTINUOUS PINK NOISE (1)	400W
CONTINUOUS POWER (2)	300W
PROGRAM POWER (3)	600W
PEAK POWER (4)	1200W
SENSITIVITY (5)	103dB
FREQUENCY RANGE (6)	100 - 6100 Hz
POWER COMPRESSION	
POWER COMPRESSION @-10DB (7)	(30W) 0,5 dB
POWER COMPRESSION @-3DB	(150W) 1,5 dB
POWER COMPRESSION @FULL POWER	(300W) 2,1 dB
MAX RECOMM. FREQUENCY	4000 Hz
RECOMM. ENCLOSURE VOLUME	4 ÷ 15 lt. (0,14 ÷ 0,53 cuft)
MINIMUM IMPEDANCE	6,5 Ohm at 25°C
MAX PEAK TO PEAK EXCURSION	13 mm (0,51 in)
VOICE COIL DIAMETER	75 mm (2,95 in)
VOICE COIL WINDING MATERIAL	aluminum
POLARITY	positive voltage on red terminal gives forward cone motion

THIELE SMALL PARAMETERS (8)

Fs	89 Hz
Re	5,5 Ohm
Sd	0,035 sq.mt. (54,25 sq.in.)
Qms	7,1
Qes	0,24
Qts	0,23
Vas	18 lt. (0,64 cuft)
Mms	30 gr. (0,07 lb)
BL	20,3 Tm
Linear Mathematical Xmax (9)	±2,5 mm (± 0,10 in)
Le (1kHz)	0,06 mH
Ref. Efficiency 1W@1m (half space)	98 dB

MOUNTING INFORMATION

Overall diameter	260 mm (10,24 in)
N. of mounting holes and bolt	4 on diam. 275 mm (4 on 10,83 in) 8 on diam. 244,5 mm (4 on 9,63 in)
Mounting holes diameter	7,15 mm (0,28 in)
Front mount baffle cutout ø	232 mm (9,13 in)
Rear mount baffle cutout ø	232 mm (9,13 in)
Total depth	96 mm (3,78 in)
Flange and gasket thickness	14,5 mm (0,57 in)
Net weight	3,5 kg (7,7 lb)
Shipping weight	3,9 kg (8,58 lb)
CardBoard Packaging dimensions	275 x 275 x 164 mm(10,83 x 10,83 x 6,46 in)

FREQUENCY RESPONSE CURVE OF 10NDA610 (AIC ON) MADE ON 30 LIT. CLOSED ENCLOSURE IN FREE FIELD (4PI) ENVIRONMENT. ENCLOSURE CLOSES THE REAR OF THE DRIVER. THE THIN LINE REPRESENTS 45 DEG. OFF AXIS FREQUENCY RESPONSE

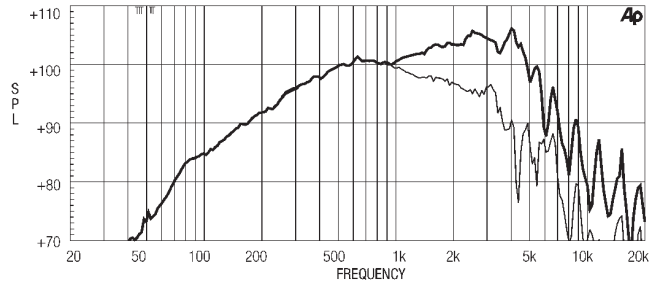

FREE AIR IMPEDANCE MAGNITUDE CURVE – AIC ON

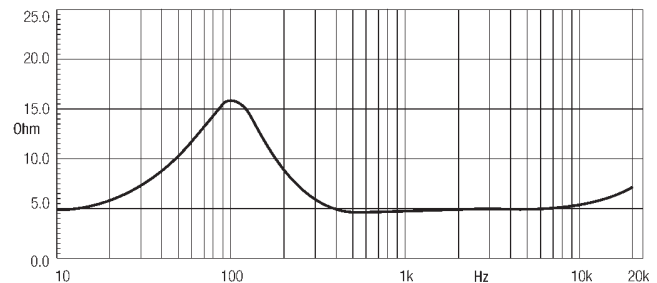

NOTES

- (1) AES standard
- (2) Continuous power rating is measured in 30 lit closed enclosure using a 100 -3000Hz band limited pink noise test signal applied continuously for 2 hours.
- (3) Program power rating is measured as for 2 above but 50% duty cycle.
- (4) The peak power rating is based on a 6dB crest factor above the continuous power rating and represents the maximum permitted instantaneous peak power level over a maximum period of 10ms which will be withstood by the loudspeaker without damage.
- (5) Sensitivity represents the averaged value of acoustic output as measured on the forward central axis of cone, at distance 1m from the baffle panel, when connected to 2,83V sine wave test signal swept between 500Hz and 2500Hz with the test specimen mounted in the same enclosure as given for 2 above.
- (6) Frequency range is given as the band of frequencies delineated by the lower and upper limits where the output level drops by 10 dB below the rated sensitivity in half space environment.
- (7) Power compression represents the loss of sensitivity for the specified power, measured from 100-1000 Hz, after a 5 min pink noise preconditioning test at the specified power.
- (8) Thiele - Small parameters are measured after the test specimen has been conditioned by 400 W AES power and represent the expected long term parameters after a short period of use.
- (9) Linear Mat. Xmax is calculated as; $(Hvc-Hg)/2+Hg/4$ where Hvc is the coil depth and Hg is the gap depth.

Eighteen Sound engages in research and product improvement. New materials and design refinements can be introduced into existing products without notice.