

10W400

Low Frequency Ferrite Transducer

Key Features

- 98 dB SPL 1W / 1m average sensitivity
- 51 mm (2 in) Interleaved Sandwich Voice coil (ISV)
- 280 Watt continuous pink noise power handling
- Ideal for compact two way and multiway systems
- Improved heat dissipation via unique basket design



General Description

The 10W400 is a 400-W-program low frequency driver designed to satisfy the need for a 10" ferrite loudspeaker combining excellent linearity with good sensitivity and power handling characteristics. It is primarily recommended for compact bass reflex systems in enclosures as small as 25 lt.

The paper curvilinear cone is carried by a dampened linen, double half-roll front suspension to control vibration modes. The 8 mm Xmax ensures good travel control and linear excursion.

The 50 mm diameter state-of-the-art, copper wire voice coil employs same technology fitted to our top-of-the-range models, that is our Interleaved Sandwich Voice coil (ISV) technology. A high strength fibreglas former carries windings on both the outer and inner surfaces to achieve a mass balanced coil. This results in an extremely linear motor assembly which, in conjunction with the highly advanced design of the magnetic structure, provides a high force factor or BL.

Another feature of our products, retained in the 10W400 are the fine air channels between the chassis back plate and the top plate of the magnet, which draw heated air out from the voice coil gap and dissipate the energy through the chassis casting.

The top and back plates of the magnet assembly have been designed to optimise flux density and BL factor in the air gap using our in-house FEA CAD facility.

0221084410 8 Ohm

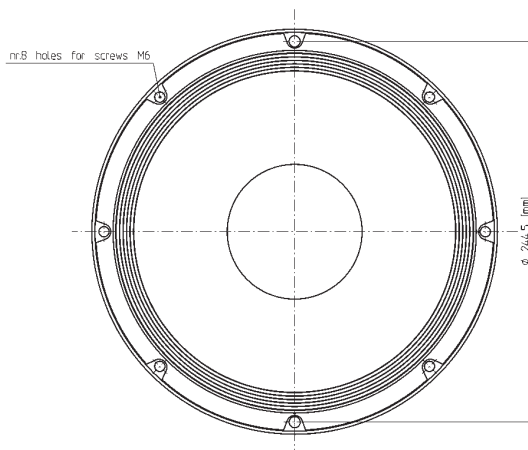
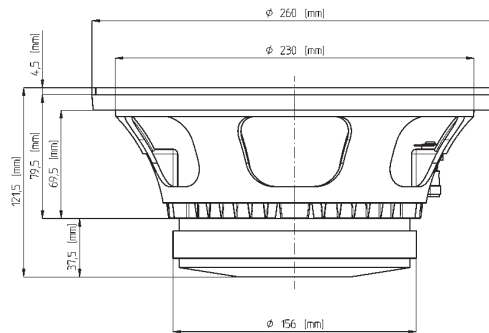

FERRITE LF-MB-MF TRANSDUCERS

10W400

Low Frequency Ferrite Transducer

GENERAL SPECIFICATIONS

NOMINAL DIAMETER	260 mm (10 in)
RATED IMPEDANCE	8 Ohm
CONTINUOUS PINK NOISE (1)	280 W
CONTINUOUS POWER (2)	200 W
PROGRAM POWER (3)	400 W
PEAK POWER (4)	800 W
SENSITIVITY (5)	98 dB
FREQUENCY RANGE (6)	55 ÷ 4500 Hz
POWER COMPRESSION @-10DB (7)	(20 W) 0,7 dB
POWER COMPRESSION @-3DB	(100 W) 1,4 dB
POWER COMPRESSION @FULL POWER	(200 W) 2,8 dB
MAX RECOMM. FREQUENCY	2500 Hz
RECOMM. ENCLOSURE VOLUME	20 ÷ 50 lt. (0,71 ÷ 1,77 cuft)
MINIMUM IMPEDANCE	6,1 Ohm at 25°C
MAX PEAK TO PEAK EXCURSION	24 mm (0,94 in)
VOICE COIL DIAMETER	51 mm (2,00 in)
VOICE COIL WINDING MATERIAL	aluminum
POLARITY	positive voltage on red terminal gives forward cone motion

THIELE SMALL PARAMETERS (8)

Fs	70 Hz
Re	5,1 Ohm
Sd	0,035 sq.mt. (54,25 sq.in.)
Qms	3,99
Qes	0,44
Qts	0,4
Vas	31 lt. (1,10 cuft)
Mms	27 gr. (0,06 lb)
BL	11,7 Tm
Linear Mathematical Xmax (9)	± 5,5 mm (± 0,22 in)
Le (1kHz)	1,2 mH
Ref. Efficiency 1W@1m (half space)	96 dB

MOUNTING INFORMATIONS

Overall diameter	260 mm (10,24 in)
N. of mounting holes	8
Mounting holes diameter	7,15 mm (0,28 in)
Bolt circle diameter	244,5 mm (9,63 in)
Front mount baffle cutout ø	232 mm (9,13 in)
Rear mount baffle cutout ø	232 mm (9,13 in)
Total depth	121,5 mm (4,78 in)
Flange and gasket thickness	14,5 mm (0,57 in)
Net weight	4,7 kg (10,38 lb)
Shipping weight	5,10 kg (11,26 lb)
CardBoard Packaging dimensions	275 x 275 x 164 mm (10,83 x 10,83 x 6,46 in)

FREQUENCY RESPONSE CURVE OF 10W400 MADE ON 30 LIT. ENCLOSURE TUNED 55HZ INFREE FIELD (4PI) ENVIRONMENT. ENCLOSURE CLOSES THE REAR OF THE DRIVER. THE THIN LINE REPRESENTS 45 DEG. OFF AXIS FREQUENCY RESPONSE

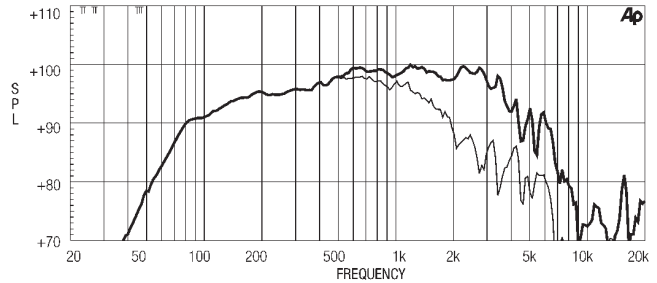

FREE AIR IMPEDANCE MAGNITUDE CURVE

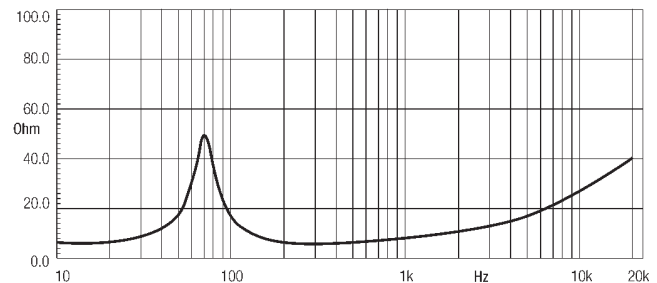

NOTES

- (1) AES standard
- (2) Continuous power rating is measured in 30 lit enclosure tuned 55Hz using a 70 - 2000Hz band limited pink noise test signal applied continuously for 2 hours.
- (3) Program power rating is measured as for 2 above but 50% duty cycle.
- (4) The peak power rating is based on a 6dB crest factor above the continuous power rating and represents the maximum permitted instantaneous peak power level over a maximum period of 10ms which will be withstood by the loudspeaker without damage.
- (5) Sensitivity represents the averaged value of acoustic output as measured on the forward central axis of cone, at distance 1m from the baffle panel, when connected to 2,83V sine wave test signal swept between 500Hz and 2500Hz with the test specimen mounted in the same enclosure as given for 2 above.
- (6) Frequency range is given as the band of frequencies delineated by the lower and upper limits where the output level drops by 10 dB below the rated sensitivity in half space environment.
- (7) Power compression represents the loss of sensitivity for the specified power, measured from 50-500 Hz, after a 5 min pink noise preconditioning test at the specified power.
- (8) Thiele - Small parameters are measured after the test specimen has been conditioned by 280 W AES power and represent the expected long term parameters after a short period of use.
- (9) Linear Mat. Xmax is calculated as; $(Hvc-Hg)/2 + Hg/4$ where Hvc is the coil depth and Hg is the gap depth.

Eighteen Sound engages in research and product improvement. New materials and design refinements can be introduced into existing products without notice.